



## Connection Technology Center, Inc.

7939 Rae Boulevard  
Victor, New York 14564  
Toll Free: (800) 999-5290  
Phone: (585) 924-5900  
Fax: (585) 924-4680

# ***Compliance with API Standard 670 the PRO Product Standard for Proximity Probes***

## **Background:**

The American Petroleum Institute (API) issued their first standard in 1924. Since then, some 500 standards for the oil, gas and power industry have been issued. API is an American National Standards Institute (ANSI) accredited standards development organization, and API Standard 670 was developed for Machinery Protection Systems. The current 4<sup>th</sup> edition is available from the API for the cost of \$174.00 USD, and can be ordered in a pdf file format. The API Standard 670 has global acceptance through active involvement with the International Organization for Standardization (ISO) and other international bodies.

Connection Technology Center, Inc. (CTC) is an ISO 9001:2008 certified manufacturer of Vibration Analysis Hardware. Started in 1995, CTC specialized in manufacturing cables and connectors for industrial vibration applications. The product line now offers accelerometers, piezo velocity sensors, junction boxes and mounting hardware providing a full range of products for measuring acceleration and velocity on industrial machinery.

In 2007, CTC formed the Protection & Reliability Optimization Instruments (PRO) division with an initiative to manufacture proximity probes, extension cables, oscillator-demodulators (drivers), and mounting hardware for the non-contact measurement of shaft displacement in fluid film bearing applications. This initiative conforms with or exceeds API Standard 670, and provides industry with a means to quantify the shaft vibration and shaft location in a fluid film bearing to avoid catastrophic bearing failure. PRO proximity probe systems provide an output of 200 mV/mil (1 mil = 0.001 inches) or 7.87 mV/ $\mu$ m when calibrated with 4140 steel in accordance with API Standard 670.

## Machinery Protection Systems:

The machinery protection systems described in API Standard 670 were developed for fluid film bearing systems that consist of a shaft, bearing sleeve, and lubricant between the shaft and sleeve. There are no rolling elements in a fluid film bearing. The shaft is supported by a lubricant as it rotates inside the sleeve. This creates the need to have a sensor that can measure the shaft vibration and shaft location inside the sleeve using a non-contact means. Typically, two proximity probes are installed on or in the bearing housing 90° apart at the radial locations as illustrated in Figure #1.

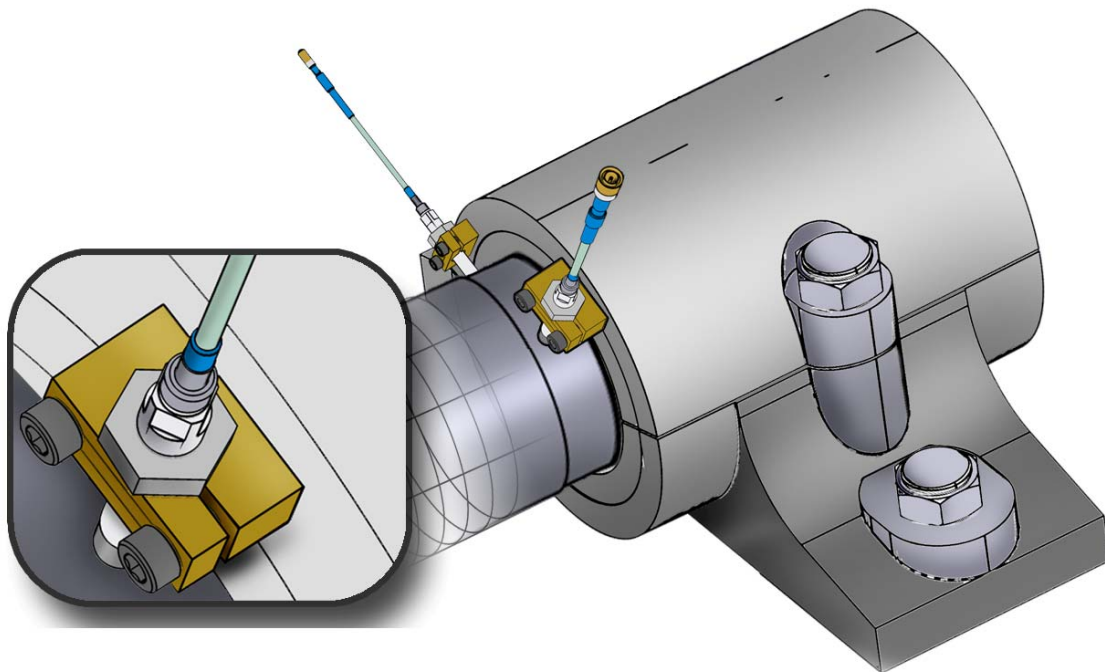

Figure #1 – Proximity Probe Mounting Diagram

Alternatively, proximity probes can also be used to measure the axial shaft position (thrust), rotational speed, keyway phase reference, case expansion, and in a reciprocating machine, piston rod drop.

Radial proximity probes are often referred to as X and Y when viewed from the driver to the driven machine component. In Figure #2, if viewed from the driver to the driven, the Y probe would be on the left and the X probe would be on the right.

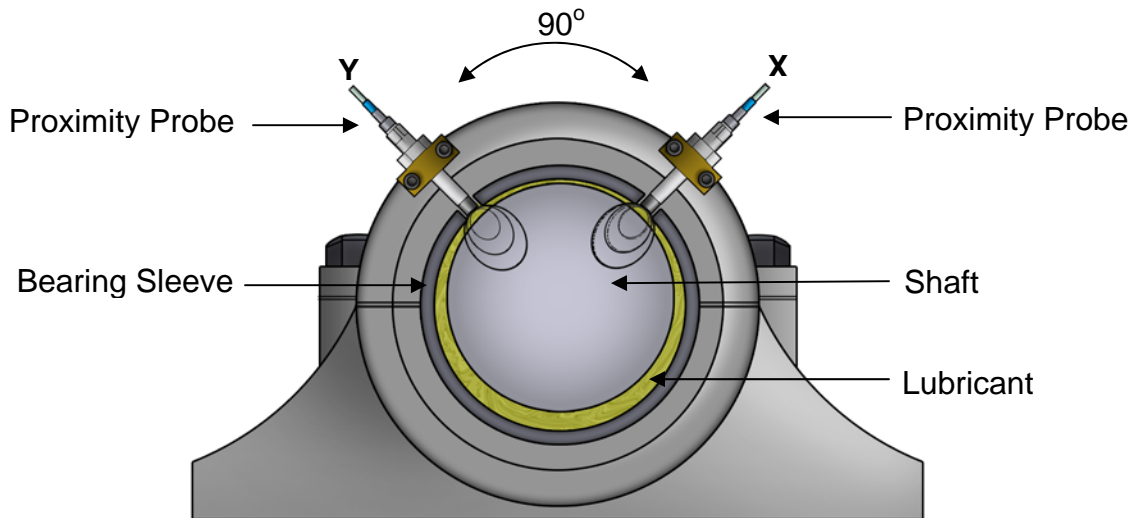

Figure #2 – X and Y Radial Proximity Probes

Figure #2 also illustrates that the X and Y proximity probes are spaced  $90^\circ$  apart from each other, and that the inside of the bearing sleeve is counter bored to prevent interference on the side of the sensing tip. The direction of rotation never determines which probe is X and which probe is Y, but the two probes can be used to identify the direction of rotation.

If the Y probe leads the X probe by a phase difference of  $90^\circ$ , the shaft is rotating clockwise.

If the X probe leads the Y probe by a phase difference of  $90^\circ$ , the shaft is rotating counter clockwise.

## System Components:

A proximity probe system is made of three specific components:

1. Probe
2. Extension Cable
3. Driver (oscillator-demodulator)

## 1. Probe:

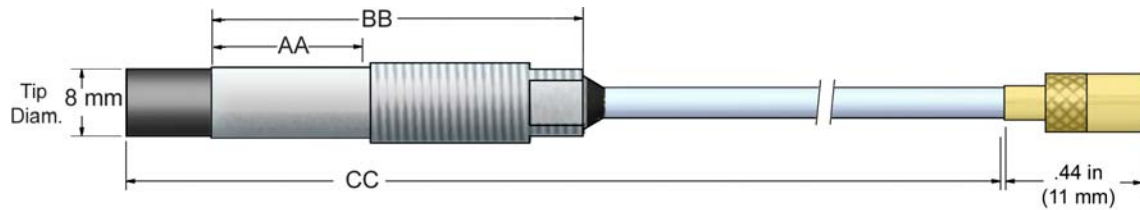

Figure #3 – Forward Mount Proximity Probe

*“API Standard 670, section 5.1.1.1 states that a proximity probe consists of a tip, a probe body, and integral coaxial cable, and a connector as specified in 5.1.3, and shall be chemically resistant as specified in 4.4.”*

PRO proximity probes are manufactured with a resilient polyphenylene sulfide (PPS) tip, stainless steel body, Teflon<sup>®</sup> jacketed cable and gold plated connectors to provide robust non-contact displacement sensors, capable of performing in harsh environments.

*“API Standard 670, section 5.1.1.2 states that unless otherwise specified, the standard probe shall have a tip diameter of 7.6 to 8.3 millimeters (0.300 to 0.327in), with a reverse mount, integral hex nut probe body approximately 25 millimeters (1in) in length and 3/8-24 UNF-2A threads.”*

PRO proximity probes for forward and reverse mounting are constructed with a 3/8-24 threaded stainless steel body (case).

The reverse mount probe body (case) is 33 millimeters (1.3 inches) in length with an integral 11 millimeter (7/16 inch) hex nut whose tip diameter is 8 millimeters (0.315 inches).

The forward mount probe, as shown in Figure #3, is available in multiple case lengths (1.0 to 9.5 inches in 0.5 inch increments), multiple unthreaded lengths (0.0 to 8.0 inches in 1.0 inch increments), and multiple overall lengths ( note that the overall length with and without an extension cable must equal 5 meters or 9 meters). Forward mount probes incorporate two 11 millimeter (7/16 inch) hex nuts for mounting purposes.

*“API Standard 670, section 5.1.1.3 states when specified, the standard options may consist of one or more of the following forward mount probe configurations.”*

a) *“A tip diameter of 7.6 to 8.3 millimeters (0.300 to 0.327 inches) and 3/8-24-UNF-2A English threads.”*

- PRO proximity probes have an 8 millimeter (0.315 inches) tip diameter.

- b) *“A tip diameter of 4.8 to 5.3 millimeters (0.190 to 0.208in) and 1/4-28-UNF-2A English threads.”*
- c) *“A tip diameter of 7.6 to 8.3 millimeters (0.300 to 0.327in) and M10x1 metric threads.”*
- d) *“A tip diameter of 4.8 to 5.3 millimeters (0.190 to 0.208in) and M8x1 metric threads.”*
- e) *“Lengths other than approximately 25 millimeters (1in).”*
  - PRO proximity probes have multiple case lengths (1.0 to 9.5 inches in 0.5 inch increments).
- f) *“Flexible stainless steel armoring attached to the probe body and extending to within 100 millimeters (4in) of the connector”*
  - PRO proximity probes have optional stainless steel armoring to protect the cable attached to the probe body and extending to within 100 millimeters (4 inches) of the connector.

*“API Standard 670, section 5.1.1.4 states that the overall physical length of the probe and integral cable assembly shall be approximately 1 meter (39in), measured from the probe tip to the end of the connector. The minimum overall physical length shall be 0.8 meters (31in); the maximum overall physical length shall be 1.3 meters (51in).”*

The integral cable length on PRO proximity probes always falls within a +30% to -0% tolerance for a 1 meter total length measured from the probe tip to the end of the connector.

*“API Standard 670, section 5.1.1.5 states that a piece of clear heat-shrink tubing (not to be shrunk at the factory) 40 millimeters (1.5in) long shall be installed over the coaxial cable before the connector is installed to assist the owner in tagging.”*

PRO proximity probe cables have a 2 inch piece of clear polyolefin heat shrink placed over the manufacturer’s part number and serial number, and an additional 2 inch piece of clear polyolefin heat shrink for the end user’s private or internal labeling.

## 2. Extension Cables:



Figure #4 – Extension Cable

*“API Standard 670, section 5.1.2 states that extension cables shall be coaxial, with connectors as specified in 5.1.3. The nominal physical length shall be 4 meters (158in) and shall be a minimum of 3.6 meters (140in). Shrink tubing shall be provided at each end in accordance with 5.1.1.5.”*

PRO extension cables have a tolerance of 4.0 meters +20% and 4.0 meters -0%. In accordance with 5.1.1.5, PRO provides two additional 2 inch pieces of clear polyolefin heat shrink for the end user’s private or internal labeling.

*“API Standard 670, section 5.1.3 states that the attached connectors shall meet or exceed the mechanical, electrical, and environmental requirements specified in Section 4 and in MIL-C-39012-C and MIL-C-39012/5F. The cable and connector assembly shall be designed to withstand a minimum tensile load of 225 Newtons (50 pounds).”*

PRO provides connectors with gold plated brass bodies, Teflon<sup>®</sup> insulators and gold plated center contacts in accordance with MIL-C-39012. Connectors are tested under tensile loads up to 75 pounds.

### 3. Driver (oscillator – demodulator):



Figure #5

*“API Standard 670, section 5.1.4 states that the standard oscillator-demodulator shall be designed to operate with the standard probe as defined in 5.1.1.2 and the probe extension cable as defined in 5.1.2.”*

*“API Standard 670 sections 5.1.4.1 states that the oscillator-demodulator output shall be 7.87 millivolts per micrometer (200 millivolts per mil) with a standard supply voltage of -24 volts DC. The oscillator-demodulator shall be calibrated for the standard length of the probe assembly and extension cable. The output, common, and power-supply connections shall be heavy-duty, corrosion-resistant terminations suitable for at least 18 American Wire Gage (AWG) wire (1.0 square*

*millimeters cross section). The oscillator-demodulator shall be electrically interchangeable in accordance with 4.6.1 for the same probe tip diameter. The interface or noise of the installed system (including oscillator-demodulator radio-frequency output noise, line-frequency interference, and multiples thereof) on any channel shall not exceed 20 millivolts pp, measured at the monitor inputs and outputs, regardless of the condition of the probe or the gap. The transducer system manufacturer's recommended tip-to-tip spacing for probe cross-talk must be maintained. The oscillator-demodulator common shall be isolated from ground. Oscillator-demodulators shall be mechanically interchangeable.”*

PRO drivers (oscillator – demodulators) have a sensitivity of 200 millivolts per mil (7.87 millivolts per micrometer) when calibrated with standard probes using a 4140 steel target. Screw terminals on the driver (oscillator-demodulator) allow for connection to a -24V power supply using wires of at least 18 AWG. The driver (oscillator-demodulator) is calibrated for the combined cable length of the probe assembly and extension cable (5 meter or 9 meter). The driver (oscillator-demodulator) is electrically interchangeable for the same probe tip diameter and total system length. The driver (oscillator-demodulator) common is isolated from ground. The driver (oscillator-demodulator) is mechanically interchangeable.

*“API Standard 670, section 5.1.4.2 states that when specified, oscillator-demodulators shall be supplied with a DIN rail mounting option.”*

PRO provides drivers (oscillator-demodulators) with multiple mounting options, the standard and most common being the DIN Rail mounting option as shown in Figure #5.

## **Accuracy:**

*“API Standard 670, section 4.5.1 states that accuracy of the transducer system and monitor system in the testing (0°C to 45°C) and operating (-35°C to 120°C) temperature ranges shall be:”*

- a) *“The Incremental Scale Factor (ISF) error is the maximum amount the scale factor varies from 7.87 mV per micrometer (200 mV per mil) when measured at 250  $\mu\text{m}$  (10 mil) increments. ISF error is associated with errors in radial vibration measurements.”*
  - *“Within testing range, +/- 5% of 7.87 mV/ $\mu\text{m}$  (200 mV/mil)”*
  - *“Outside testing range but within operating range, an additional +/- 5% of the testing range accuracy.”*
  
- b) *“The Deviation from Straight Line (DSL) error is the maximum error (in mils) in the probe gap reading at a given voltage compared to a 7.87 mV per micrometer (200 mV per mil) best fit straight line. DSL errors are associated with errors in axial position or probe gap measurements.”*

- “Within testing range, +/- 25.4  $\mu\text{m}$  (+/- 1 mil) of the best fit straight line at a slope of 7.87 mV/ $\mu\text{m}$  (200 mV/mil)”
- “Outside testing range but within operating range, +/- 76  $\mu\text{m}$  (+/- 3 mils) of the best fit straight line at a slope of 7.87 mV/ $\mu\text{m}$  (200 mV/mil)”

c) “The Minimum Linear Range shall be 2 millimeters (80 mils).”

The ISF Error of PRO proximity probe systems is illustrated in Figure #6, and complies with the API Standard 670 testing range.

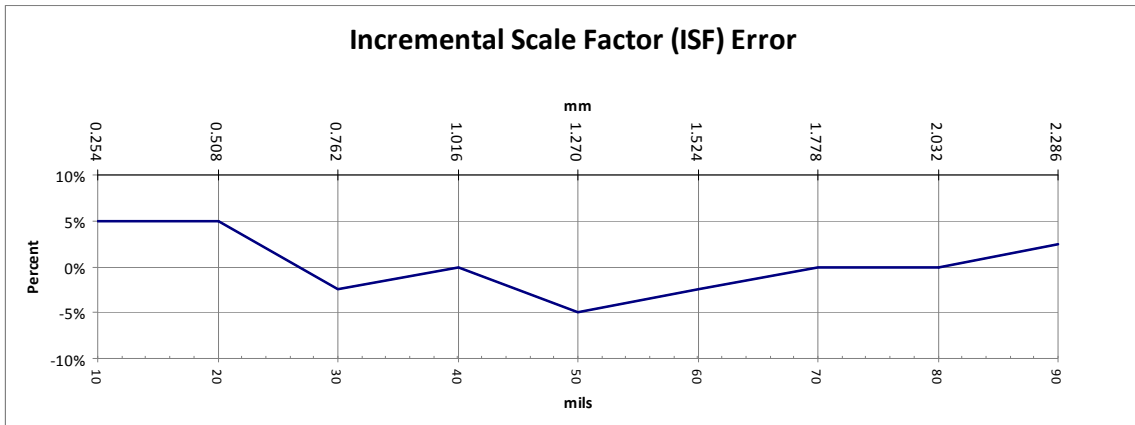

Figure #6 – ISF Error

The DSL Error of PRO proximity probe systems is illustrated in Figure #7, and complies with the API Standard 670 testing range.

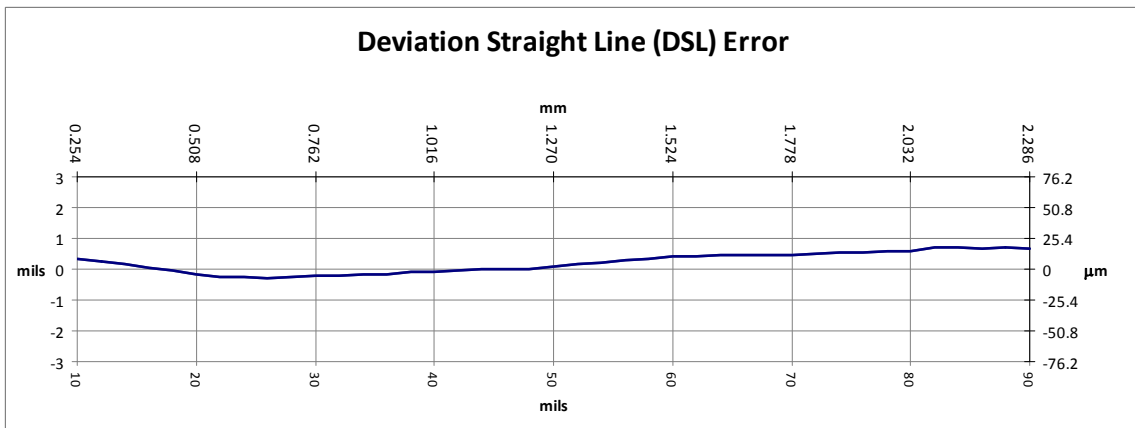

Figure #7 – DSL Error

The gap to voltage Linear Range of PRO proximity probe systems is illustrated in Figure #8, and exceeds the API Standard 670 testing range.

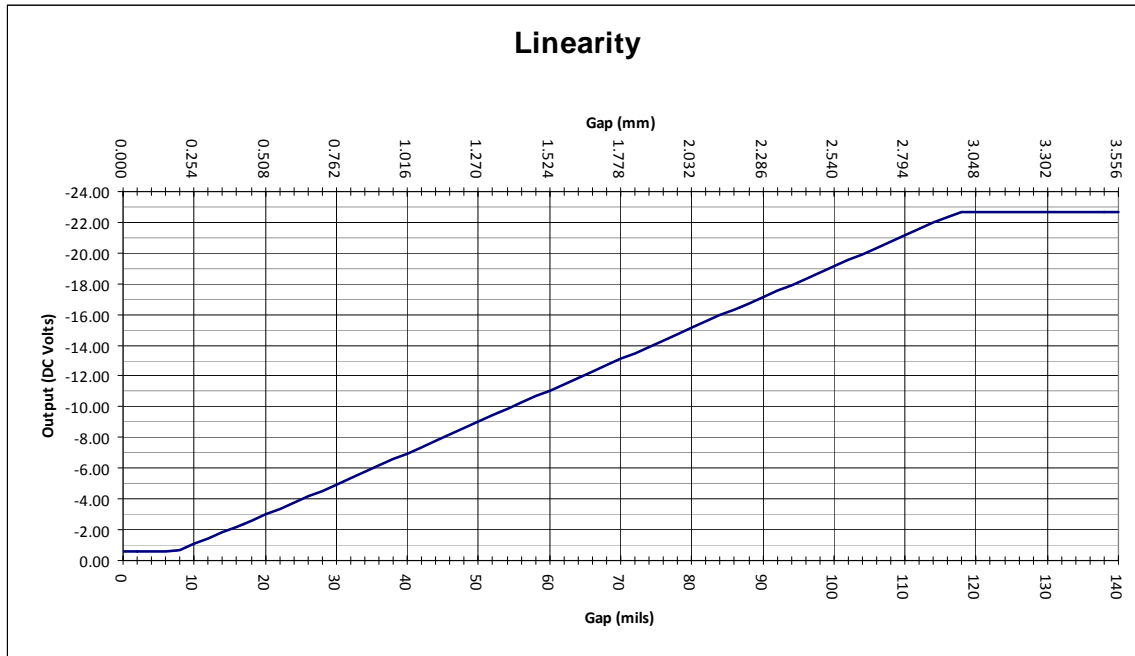

Figure #8 – Gap to Voltage Linear Range

*“API Standard 670, section 4.5.2 states that if monitoring system components or transducer system components will be used in applications exceeding the requirements of the testing or operating ranges, the machinery protection hardware vendor shall supply documentation showing how the accuracy is affected or suggest alternative transducer and monitor components suitable for the intended application.”*

PRO would consider this on a case by case basis and provide accurate data sheets based on the application or suggest an alternative measurement.

*“API Standard 670, section 4.5.3 states that the proximity probe transducer system accuracy shall be verified on the actual probe target area or on a target with the same electrical characteristics as those of the actual probe target area.”*

PRO component systems are calibrated to 4140 steel, unless a custom calibration based on an alternative material is requested at the time of customer order.

*“API Standard 670, section 4.5.4 states that when verifying the accuracy of any individual component of the proximity probe transducer system in the operating range, the components not under test shall be maintained within the testing range.”*

PRO proximity probes, extension cables, and drivers (oscillator – demodulators) are all tested at the extended temperature ranges within the guidelines of API Standard 670.

## Summary:

API Standard 670 is a well written and meaningful guideline for use with fluid film bearing applications. In a fluid film bearing, the shaft rotation is supported by a lubricant in the bearing sleeve allowing the shaft to freely vibrate and seek a centerline that may very well not be the geometric center of the bearing sleeve.

Following the guidelines of API Standard 670, proximity probes can be installed 90° apart in the radial X & Y locations of the bearing to measure the vibration and the shaft centerline location.

The vibration of the shaft will be measured as a variable DC voltage that simulates an AC vibration signal. This measurement is typically made in mils peak to peak or  $\mu\text{m}$  peak to peak. The radial vibration measurement can be used to quantify the total amount of shaft vibration in the X and Y directions. In many applications these two measurements are combined to form a shaft orbit plot as shown in Figure #9.

The shaft orbit that is developed by combining the X & Y measurements of the radial proximity probes can be used to measure the total vibration of the shaft centerline as it rotates in the bearing sleeve. The orbit will provide the peak to peak displacement and direction of vibration relative to the shaft centerline.

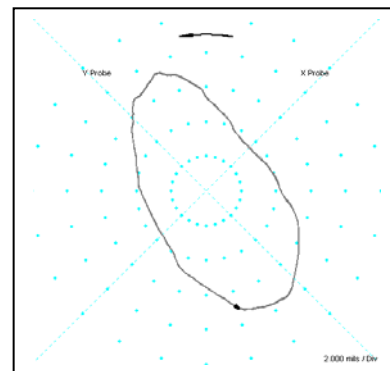

Figure #9 – Shaft Orbit

The location of the shaft centerline in the bearing sleeve can also be measured with the radial proximity probes. This DC voltage (gap) measurement is typically expressed in mils or  $\mu\text{m}$  and is an actual measurement of the spacing between the shaft surface and tip of the proximity probe. This measurement is critical in knowing the location of the shaft in the bearing sleeve, and preventing metal to metal contact between the shaft and the bearing sleeve.

Alternatively, proximity probes can also be used to measure the axial shaft position (thrust), rotational speed, keyway phase reference, case expansion, and in a reciprocating machine, piston rod drop.

All of these critical measurements require proximity probes, extension cables, and drivers (oscillator-demodulator) that are robust and accurate as described in API Standard 670.

**The PRO Standard of meeting or exceeding the requirements of API Standard 670 will provide the user with:**

- Proximity probes that are manufactured with a resilient polyphenylene sulfide (PPS) tip, stainless steel body, Teflon<sup>®</sup> jacketed cable and gold plated connectors to provide robust non-contact displacement sensors, capable of performing in harsh environments.
- Teflon<sup>®</sup> jacketed extension cables provide connectors with gold plated brass bodies, Teflon<sup>®</sup> insulators and gold plated center contacts in accordance with MIL-C-39012. Connectors are tested under tensile loads up to 75 pounds.
- Drivers (oscillator – demodulators) that have a sensitivity of 200 millivolts per mil (7.87 millivolts per micrometer) when calibrated with standard probes using a 4140 steel target. Screw terminals on the driver (oscillator-demodulator) allow for connection to a -24V power supply using wires of at least 18 AWG. The driver (oscillator-demodulator) is calibrated for the combined cable length of the probe assembly and extension cable.
- An ISF error less than +/-5% of 200 mV/mil (7.87 mV/ $\mu\text{m}$ ) when measured at 10 mil (250  $\mu\text{m}$ ) increments.
- A DSL error less than +/- 1 mil (+/- 25.4  $\mu\text{m}$ ) of the best fit straight line at a slope of 200 mV/mil (7.87 mV/ $\mu\text{m}$ ).
- A Linear Range exceeding 80 mils (2 mm).
- **PRO and Bently<sup>™</sup> compatible Proximity Probes, Extension Cables, and Drivers (Oscillator-Demodulators) that meet or exceed the criteria established by API Standard 670.**



# Certificate of Registration

**QUALITY MANAGEMENT SYSTEM - ISO 9001:2008**

*This is to certify that:*

**Connection Technology Center Inc.  
7939 Rae Boulevard  
Victor  
New York  
14564  
USA**

*Holds Certificate No:* **FM 76123**

*and operates a Quality Management System which complies with the requirements of ISO 9001:2008 for the following scope:*

The design and manufacture of vibration analysis equipment, cable assemblies, switchboxes and connectors.

This certificate is traceable to this company's original registration certificate Number US-1791 dated July 5, 2000 and issued by Intertek.

*For and on behalf of BSI:*

*President, BSI America, Inc.*

Originally Registered: **07/14/2003**

Latest Issue: **08/31/2009**

Expiry Date: **09/08/2012**



Page: 1 of 1

This certificate remains the property of BSI and shall be returned immediately upon request.  
An electronic certificate can be authenticated [online](http://www.bsigroup.com/ClientDirectory). Printed copies can be validated at [www.bsigroup.com/ClientDirectory](http://www.bsigroup.com/ClientDirectory)  
To be read in conjunction with the scope above or the attached appendix.  
Americas Headquarters: 12110 Sunset Hills Road, Suite 200, Reston, VA 20190, USA.

